



PMC05S180

3.6 WATT

DALI POWER SUPPLY



Features

- * Universal AC Input Range 90~305Vac
- * Output Constant Current Design
- * Continuous Short Circuit Protection
- * EMC Meet EN55022/EN55015 Class B
- * PSE J61347-1, J61347-2-13, J55015
- * Power Supply for DALI Systems (DALI Protocol) for Remote Mounting

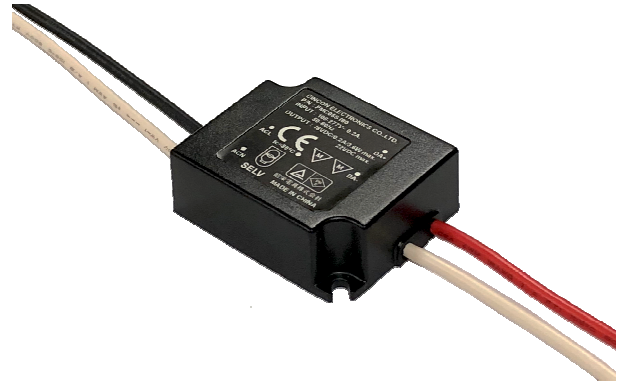

| MODEL | INPUT VOLTAGE RANGE | OUTPUT OPERATING VOLTAGE | OUTPUT RATED CURRENT | OUTPUT RATED POWER | OUTPUT VOLTAGE MAXIMUM | RIPPLE % NOISE (Max.) NOTE2 |
|-----------|---------------------|--------------------------|----------------------|--------------------|------------------------|-----------------------------|
| PMC05S180 | 90~305Vac | 9.5 ~ 18V | 200mA | 3.6W | 22V | 1% Vo |

Note:

1. Nominal Input Voltage: 115Vac, 230Vac
2. Ripple and Noise are measured at rated current, 115Vac/ 230Vac, Vo=18Vdc and 20MHz bandwidth with a 0.1uF ceramic capacitor.
3. Measured at rated current, 115Vac/ 230Vac, Vo=18Vdc

Installation Drawing

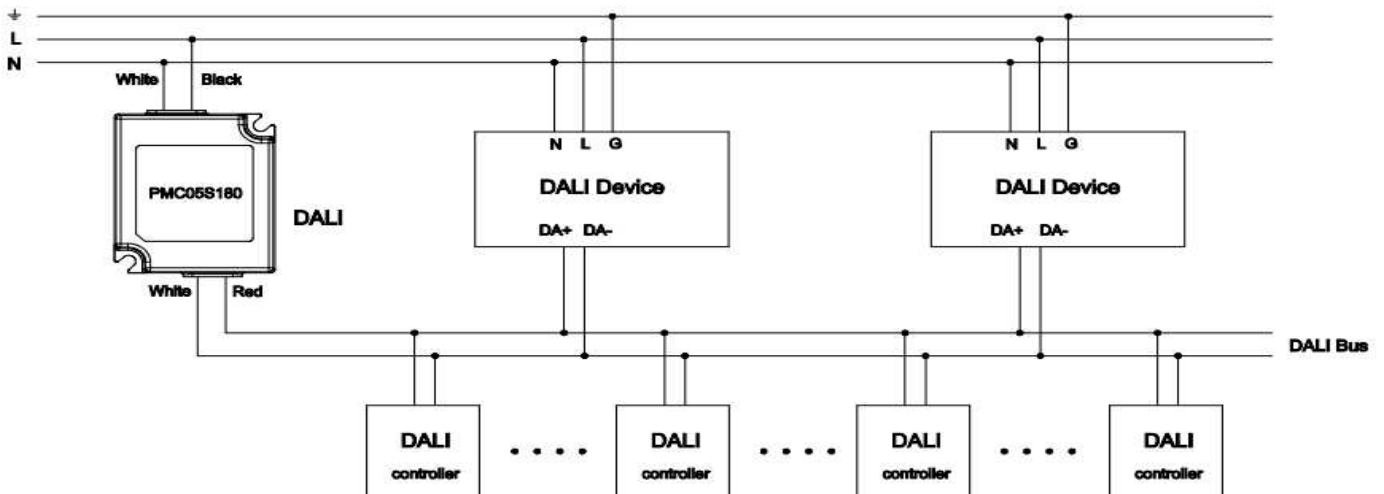

Specifications

All specifications are Typical at nominal line, full load and 25°C unless otherwise noted

INPUT SPECIFICATIONS:

AC Input Voltage 90~305Vac
 Frequency 50 to 60Hz
 Leakage Current 0.75mA max

OUTPUT SPECIFICATIONS:

Output Voltage Accuracy at no load 22V max.
 Output Voltage Accuracy at full load (note1) 16V±10%.
 Constant Current Accuracy 220mA±20mA
 Current Line Regulation (note2) ±5% max.
 Over Voltage Protection Voltage Clamp by TVS
 Short Circuit Protection Constant Current with Auto Recovery
 Start up time 2.0 second max.

GENERAL SPECIFICATIONS:

Isolation voltage, Input to output 3.75KVac
 Isolation resistance, Input to output 10⁸Ω min.
 Operating Ambient Temperature -20 ~ 50°C
 Cooling Natural Convection
 Storage Temperature -40 ~ 85°C
 Operating Humidity 10%~80%RH non-condensing.
 Operating Altitude 3000m
 Vibration 0~500Hz, 2G 60min./1cycle, period for 3hours, 3 axes
 Shock 30g peak, half sine, 6 axes
 MTBF,MIL-HDBK-217F (25°C)1000Khrs min.

PMC05 Derating Curve

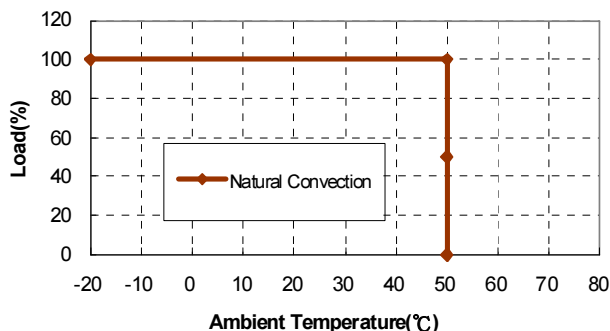

SAFETY AND EMISSIONS:

EMI EN55022/EN55015 Class B
 EMS EN61000-3-2 Harmonic Class A, EN61000-3-3
 Dimensions 1.700x1.402x0.600 Inch (243.20x35.60x15.2 mm)
 PSE.....J61347-1,J61347-2-13,J55015
 Weight 30g.
 Case Material Plastic

NOTE:

1. Output voltage is measured at full load @25°C. (C.R mode 80Ω).
2. Current Line regulation is measured from High Line to Low Line at full load.

Mechanical Specification

All Dimensions are in inches(mm)
 Tolerance:Inches:X.XXX±0.02
 Millimeters:X.XX±0.5
 UNIT : inches(mm)

